



- Fabricado en resina de poliéster y fibra de vidrio.
- Acabado de la pieza con gel-coat
- Reja en acero inoxidable o plástico
- Cumple con la normativa europea de no tener orificios superiores a 8 mm y no tener una velocidad superior a 0.5 m/s.
- Se suministra con salidas para encolar tubo de diámetro 75, 90, 110, 125, 140, 160 y 200 mm.
- Válvula hidrostática opcional (código 27138)
- Manufactured in polyester resin and fiber glass.
- Finished in gel-coat
- Grill made of stainless steel or plastic.
- According the European norm, it has holes inferior than 8mm and less than 0.5 m/s of speed.
- It is supplied with connections to glue tube of diameter 75, 90, 110, 125, 140, 160 and 200 mm.
- Optional hydrostatic valve (code 27138)

**TABLA DE CARACTERÍSTICAS / CHARACTERISTICS TABLE**

Sumidero de poliéster y fibra de vidrio 355mm x 355mm Main Drain of polyester and FPR 355mm x 355 mm							
Código Code	20282	20283	20284	22359	22360	22361	22362
Reja Grill	Inox stainless steel	Inox stainless steel	Inox stainless steel	Plástico Plastic	Plástico Plastic	Plástico Plastic	Plástico Plastic
Conexión (Ø) Connection (Ø)	75	90	110	75	90	110	125
Caudal (m3/h) Flow (m3/h)	18	27	33,5	18	27	42	45
Peso Neto (kg) Net weight (kg)	5	5	5	4,5	4,5	4,5	4,5

\*MAX. FLOW RECOMENDED IN THE GRILL/CAUDAL MAX. RECOMENDADO EN LA REJA 45 m3/h (0,5 m/s)

Sumidero de poliéster y fibra de vidrio 515mm x 515 mm Main Drain of polyester and FPR 515mm x 515 mm										
Código Code	20285	20286	20287	20288	20289	28709	28710	28711	28712	28713
Reja Grill	Inox stainless steel	Inox stainless steel	Inox stainless steel	Inox stainless steel	Inox stainless steel	Plástico Plastic	Plástico Plastic	Plástico Plastic	Plástico Plastic	Plástico Plastic
Conexión (Ø) Connection (Ø)	110	125	140	160	200	110	125	140	160	200
Caudal (m3/h) Flow (m3/h)	42	51	66	95	103	42	51	66	95	103
Peso Neto (kg) Net weight (kg)	11.5	11.5	11.5	11.5	11.5	11.5	11.5	11.5	11.5	11.5

\*MAX. FLOW RECOMENDED IN THE GRILL/CAUDAL MAX. RECOMENDADO EN LA REJA 103 m3/h (0,5 m/s)

**DIMENSIONES / DIMENSIONS**

Código	Ø	A ( mm )	B ( mm )	C ( mm )	D ( mm )	volumen
20282	75	330	252	245	130	0,047
20283	90	330	252	245	130	0,047
20284	110	330	252	245	130	0,047
22359	75	330	252	245	130	0,034
22360	90	330	252	245	130	0,034
22361	110	330	252	245	130	0,034
22362	125	330	252	245	130	0,034
20285	110	512	412	363	188	0,132
20286	125	512	412	363	188	0,132
20287	140	512	412	363	188	0,132
20288	160	512	412	363	188	0,132
20289	200	512	412	363	188	0,132
28709	110	512	412	363	188	0,132
28710	125	512	412	363	188	0,132
28711	140	512	412	363	188	0,132
28712	160	512	412	363	188	0,132
28713	200	512	412	363	188	0,132

\* Dimensiones aproximadas / Approximate dimensions

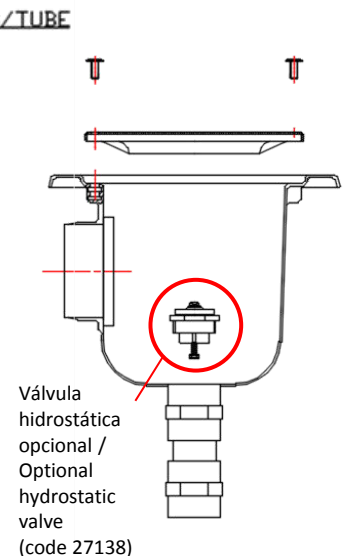
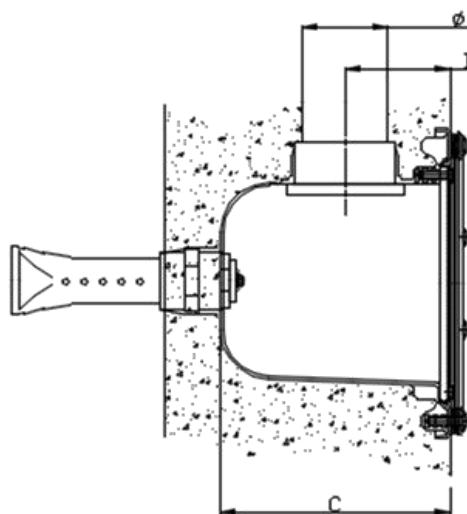
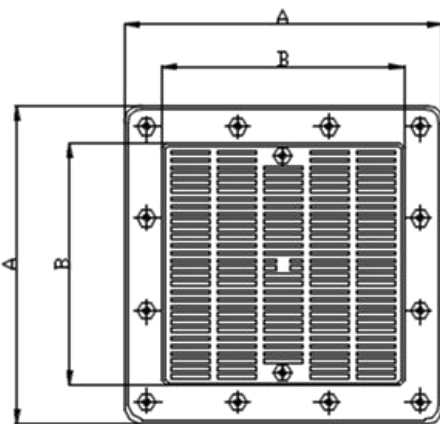
**EMBALAJE / PACKAGING**

Model Modelo	Packaging type Tipo de embalaje	Box dimension Dimensiones (m)	Box dimension with hydrostatic valve Dimensiones (m)
20282-20283-20284-22359-22360 22361-22362	Cardboard Caja cartón	0,4x0,4x0,3	0,4x0,4x0,43
20285-20286-20287-20288-20289 28709-28710-28711-28712-28713	Cardboard Caja cartón	0,57x0,57x0,42	0,57x0,57x0,55